

The GENERAL RADIO EXPERIMENTER

VOL. 2 NO. 3

AUGUST, 1927



Further Data on New A. C. Tubes

By HORATIO W. LAMSON, Engineering Department

At the present time so much interest is centered around the new A.C. tubes that we believe further information concerning them will be of interest to our readers. We are indebted for much of the following data to an Engineering Bulletin recently issued by the E. T. Cunningham Laboratories.

In the July issue of the "Experimenter" we discussed the general principles of operation of two distinct types of A.C. tubes, namely: the -26 A.C. Filament Type (UX-226 or CX-326) and the -27 Separate Heater Type (UY-227 or C-327).

The -26 type of tube is designed for use as a radio or an audio amplifier and has the same characteristics as the UX-201A or CX-301A, except that the mutual conductance is somewhat higher. It is equipped with the standard UX four prong base and has an oxide-coated ribbon type of filament which is heated with "raw A.C." consuming, however, a larger current at a lower voltage than the D.C. tubes, i.e., 1.05 amperes at 1.5 volts A.C. (For detailed specifications of these tubes see the July issue of the "Experimenter.")

It has been found possible, by a careful choice of filament current and voltage ratings, to obtain a close balance between the electromagnetic and electrostatic fields set up within the tubes by the alternating current, thereby minimizing the so-called "grid effect" of the filament and other undesirable conditions. This balance is made to occur under the condition at which the tube operates most successfully as an amplifier.

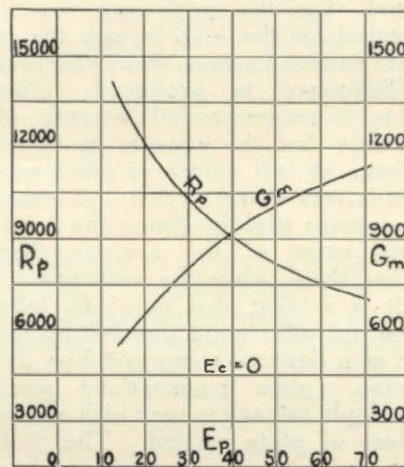

FIGURE 1

Figure 1 shows the plate impedance R_p and mutual conductance G_m of this tube plotted against the effective plate voltage E_p . It should be noted that the curve is drawn for the case of zero grid voltage, which, of course, is not the normal operating condition. The curve may be used, however, to obtain the ordinate values, corresponding to any magnitude of grid bias, by determining the "effective plate voltage" in each case, that is, by subtracting from the actual plate voltage the product obtained by multiplying the grid bias voltage by the amplification constant M_u of the tube. For example, if the tube is being used with 135 volts on the plate and with -12 volts grid bias, the effective plate voltage is $[135 - (12 \times 8.2)]$ or 36.6 volts. Thereby we see from the curves that the plate resistance and mutual conductance are 9600

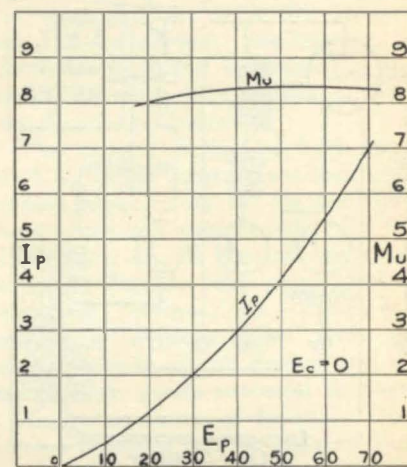

FIGURE 2

ohms and 870 micromhos respectively.

Figure 2 shows the plate current I_p and amplification constant M_u plotted against the effective plate voltage.

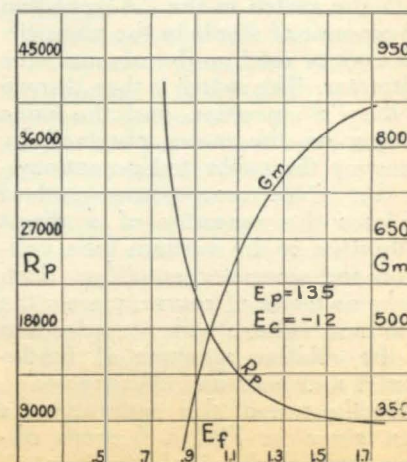

FIGURE 3



any modulation of the carrier is not appreciable unless the radio frequency stages are unstable and tend to oscillate. The radio frequency grid returns may be connected to the center tap of a resistance across the filaments as they do not require a critical adjustment. R. F. bypass condensers across this resistance are sometimes advisable.

The —27 is a tube of the indirectly heated type, having a cathode, or electron-emitting member, consisting of an oxide-coated metal cylinder in place of the usual filament. Inside of this cylinder, and insulated from it, is placed the heater filament which requires 1.75 amperes and 2.5 volts A.C. For this reason the tube cannot be operated in parallel from the transformer winding supplying the —26-tubes. Other considerations of circuit design likewise make it desirable to have a separate winding for this tube. The —27 is also similar in characteristics to the UX-201A or CX-301A, although it is slightly higher in mutual conductance and considerably lower in inter-electrode capacity. This tube is intended primarily as a detector used in conjunction with the —26 and is mounted on a special five-prong base. The —27 is particularly adapted to detector service because of its freedom from ripple voltage at low plate currents, which permits the use of either grid leak or grid bias detection. When detector sensitivity is not an important factor grid bias detection (plate rectification) may be used. A greater amount of audio amplification may be employed when using the —27 tube as a detector rather than any of the "raw A.C." types. Figures 9 and 10 show the variation of R_p , G_m , I_p , μ , with respect to effective plate voltage in the case of the —27 type, while Figure 8 indicates its extreme freedom from ripple.

Since the —27 tube uses an indirectly heated cathode it takes longer for it to reach an operating temperature than is the case with tubes in

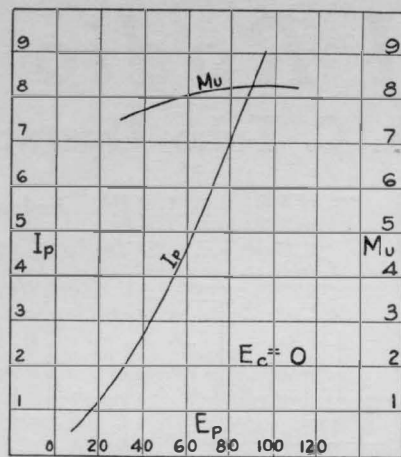

FIGURE 10

which the cathode is heated directly. The curve in Figure 11 shows that an average tube starts to operate at about twenty seconds and comes to normal operation at the end of thirty to forty seconds after the heating current is turned on.

To compete successfully with battery receivers it is essential that sets employing A.C. filament tubes com-

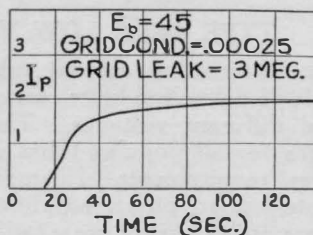

FIGURE 11

pare favorably with them in respect to all important operating characteristics, including tone quality, volume, sensitivity, selectivity, and freedom from hum, power line disturbances, and service troubles. The cost and weight of component parts is also an important consideration.

One of the most important requisites for obtaining true tone quality is the use of a tube in the last stage of the audio amplifier that is designed to handle the necessary power output without distortion. In this respect the Type UX-171 or CX-371 is strongly recommended. Used only in the last stage, the filament of this tube may be heated directly with "raw A.C." at the proper voltage and, with a center tap resistance for grid return and the proper bias and plate voltages, the operation will be about as satisfactory as if the filament were heated by a storage battery.

The sensitivity and selectivity of the radio frequency stages is essentially the same with the —26 tubes as with the —01A. The high mutual conductance of the —26 is partly offset by the necessity of using a grid bias, which is contrary to common practice in the use of the D.C. tubes. The sensitivity of the detector plays an important part in determining the

overall sensitivity of the receiver. When the —27 type is used grid leak detection is practical so that equal detector sensitivity, as compared with battery operated receivers, is obtained.

With respect to freedom from hum, the —26 and —27 combination affords very satisfactory results if the proper precautions with respect to circuit design are followed. The ripple voltage given by each type, shown on the attached curves, is actually a combination of 60 cycle and 120 cycle components with a small amount of higher harmonics. A direct comparison under operating conditions shows that the amount of ripple voltage introduced by the A.C. filament supply is of the same order of intensity as that given by the better types of plate supply devices and is not audible more than a few inches from the loudspeaker.

To obtain freedom from line disturbances care must be taken to prevent the direct pick-up of such disturbances by the tubes and associated equipment. Power transformers should be shielded if placed in the same cabinet with the receiver and, under certain conditions, an electrostatic shield between the primary and secondary windings of the transformer is desirable.

The rugged design of both types of A.C. tubes insures freedom from service troubles as far as the tubes themselves are concerned. By the elimination of all devices requiring corrosive liquids, the possibility of corroded connections disappears and it is evident that, with the proper care in circuit design and the use of high grade material in parts, a greater measure of freedom from service troubles can be secured than has been possible with previous designs of radio receivers. Furthermore, the annoyance of storage battery attention or the trouble and expense of dry cell renewals is removed by the use of a receiver which draws all of its electrical power from a convenient house-lighting socket.

With respect to the cost and bulk of component parts, this A.C. tube combination is particularly satisfactory since the use of a heavy and expensive A filter system or A supply unit is avoided, for the necessary A voltages may be obtained merely by adding a few turns of wire to the power transformer supplying the plate supply unit or by the use of a small separate transformer designed for this purpose.

The combination of the —26 tubes as radio and audio amplifiers with the —27 as a detector, makes possible the same overall performance, tube for tube, as is obtainable with battery operated receivers.

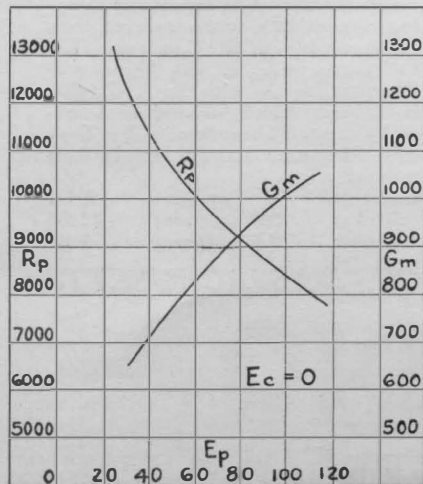

FIGURE 9

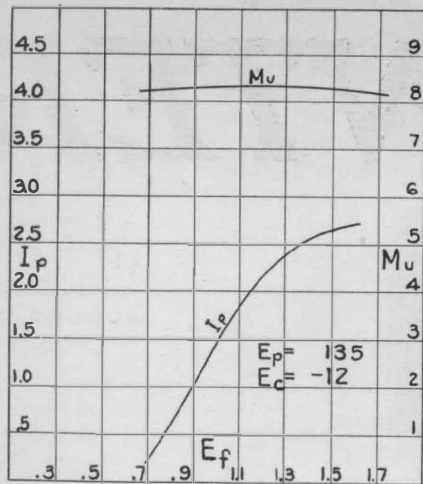

FIGURE 4

Figures 3 and 4 show the variation of R_p , G_m , I_p and M_u as the filament voltage E_f is varied. The flatness of the R_p curve from 1.3 to 1.7 volts on the filament indicates that the tube is relatively insensitive to voltage fluctuations over this range and hence is not bothered by variations in the supply line.

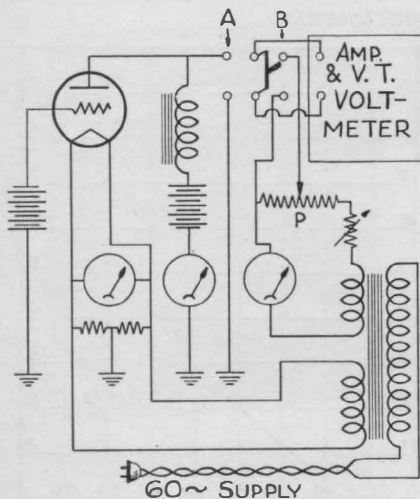

FIGURE 5

Figure 5 gives the circuit arrangement whereby the amount of "ripple voltage" in the plate circuit of a tube, heated with A. C., may be measured by comparison with a known voltage from the same source. With the switch in the "A" position the amount of ripple in the plate circuit may be read on the vacuum tube voltmeter. The switch is then thrown to the "B" position and the same reading on the meter obtained by adjusting the calibrated potentiometer P. This comparison method obviates the necessity of a direct calibration of the vacuum tube voltmeter and associated amplifier. Such a scheme gives, of course, merely the total hum voltage with no indication of the relative amounts of fundamental and harmonic frequencies.

By the use of this apparatus the data given in Figure 6 were obtained. Here the ripple (millivolts) existing in the plate circuit of the

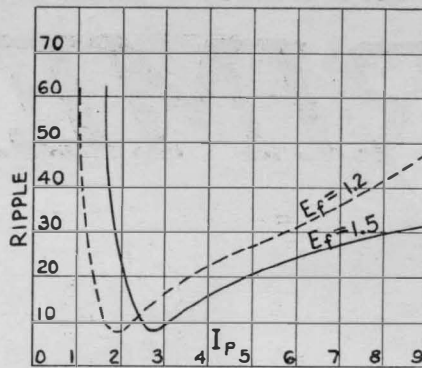

FIGURE 6

—26 tube at various values of plate current is shown. The values of plate current were chosen as abscissae instead of plate voltage in order to bring out the fact that minimum hum occurs at a plate current of about three milliamperes, the exact position varying only slightly with changes in grid voltage, but to a larger extent with changes in filament voltage as indicated in the dotted curve which shows the readings obtained when the filament voltage is reduced to 1.2. It will be noted that the grid bias recommended for the —26 is such that a plate current between three and four milliamperes is produced. This value is recommended because of the fact that the increase in ripple voltage at low values of plate current is very sharp so that it is better to operate slightly above the minimum point of the average tube rather than below the minimum.

It is evident that the —26 tube does not offer good possibilities for use as a detector using grid bias detection (plate rectification) since the ripple voltage is very high at low values of plate current. The very low minimum of hum obtained when the proper value of plate current is maintained results in an excellent performance of the tube when used as a radio frequency or audio frequency amplifier.

In Figure 7 the —26 tube is compared with Types CX-112 and CX-301A, the latter tubes being adjusted to their best operating point. A large reduction in ripple voltage, accomplished by the special filament design chosen for the —26, is clearly indicated in this figure.

It is essential for the correct operation of the —26 tube that the grid and plate returns (C+ and B-) be connected to the exact center or neutral point of the A.C. supply system, particularly when the tube is used as an audio frequency amplifier. The rapid rise in ripple voltage with departure from the correct balance point is shown in Figure 8.

To satisfy this condition the grid return may be attached to the center point of a resistance unit connected

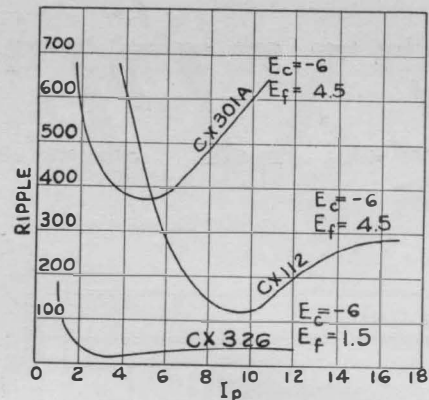

FIGURE 7

directly across the filament terminals. Under certain conditions it may be desirable to employ a low resistance potentiometer, affording thereby an adjustable center tap which will allow for the eccentricities of individual tubes or variation in the supply line balances.

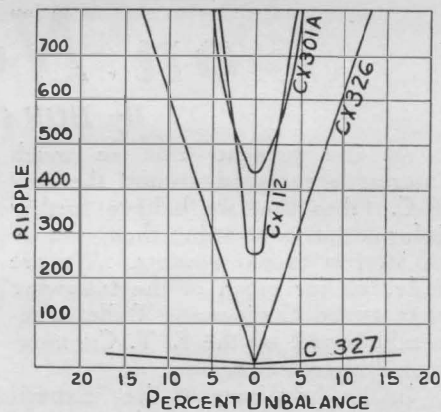

FIGURE 8

A comparison of the ripple voltage from four types of tubes is shown in Figure 8, the minimum for the CX-301A and CX-112 being slightly higher than in the previous figure since they were operated at five volts on the filament when taking these data. This curve shows the much lower minimum given by the —26 and also indicates that the grid return adjustment is less critical. We see that the grid return on the —27 type of tube is not at all critical because of the use of a separate heater element.

The —26 tube gives essentially the same performance as the UX-201A or CX-301A when used as a radio frequency amplifier since the inter-electrode capacity and other characteristics are practically identical. It is necessary in this case, however, to use a grid bias because, unlike storage battery tubes, operation without grid bias causes an uneven flow of grid current, resulting in a modulation and distortion of the incoming radio frequency signals, together with a marked decrease in amplification. When operated at the recommended grid bias, however, the ripple voltage is so low that



General Radio Parts

for A. C. Tube Operation

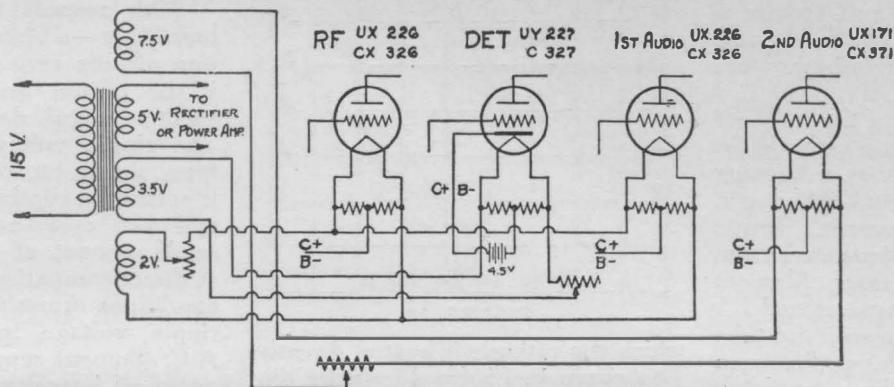

For the past several seasons the trend has been toward complete battery elimination. Many satisfactory plate supply units operating from A. C. have been developed, but filament operation from an A. C. source has presented more of a problem, due to the larger currents required and increased expense in the rectifier and filter circuit.

The newly announced A. C. tubes offer an excellent solution to this problem.

The above diagram shows how to adapt the filament wiring of the popular type of receiver to A. C. operation by use of General Radio parts especially designed for this purpose.



TYPE 440-A LOW VOLTAGE TRANSFORMER

The alternating current tubes require a source of low voltage capable of delivering large current. The various types of tubes require several different voltages. The Type 440-A Transformer supplies voltages for all popular tubes and sufficient current for all ordinary receiver requirements. Filament supply is provided for filament, separate heater, power amplifier and rectifier tubes. The following voltages and currents are available. Pri. 115 V (for lines 105-125 volts), 60 cycles:

Sec. 2 volts.....	10	amperes
3.5 volts.....	5	amperes
5 volts.....	2.5	amperes
7.5 volts.....	2	amperes

Price \$10.00

TYPE 439 RESISTANCE

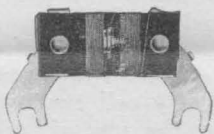

The new tubes for alternating current operation require a resistance with center tap across the filament or heater. In the filament type of tube the center tap provides the point of connection for the positive grid and negative plate potential source. The Type 439 Resistance is designed to mount directly across the filament or heater terminal of any tube socket on which it may be used.

Price 60 cents

TYPE 438 SOCKET

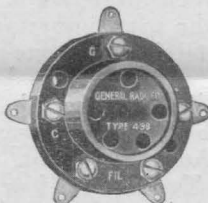

All of the new A. C. tubes, with the exception of the Type UY-227 or C-327 detector tubes, have a standard UX or CX four prong base and mount in the General Radio Type 349 Socket. The new Type UY-227 or C-327 detector tube, however, has a separate heating element, and has consequently a five prong base which requires a socket especially designed with five prong contacts. The Type 438 Socket is designed for the UY-227 or C-327 tubes.

Price 50 cents

TYPE 410 RHEOSTATS

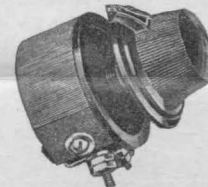

The new A. C. tubes require low resistance rheostats capable of carrying appreciably more current than those used with D. C. tubes. The resistance wire of the Type 410 Rheostat for use with the A. C. tubes is of brass, tightly wound on a specially treated fibre strip. The Type 410 Rheostat has the single hole mounting.

Resistance	Current	Price
.5 ohm	3.5 amperes	\$1.25
1.5 ohm	2.0 amperes	1.25

GENERAL RADIO COMPANY

CAMBRIDGE, MASSACHUSETTS

GENERAL RADIO

PARTS and ACCESSORIES